

CS3245

Information Retrieval

12

Lecture 12: Crawling and
Link Analysis

Last Time



Chapter 11

1. Probabilistic Approach to Retrieval / Basic Probability Theory
2. Probability Ranking Principle
3. OKAPI BM25

Chapter 12

1. Language Models for IR



Today – The Web

Chapter 20

- Crawling

Chapter 21

- Anchor Text
- PageRank

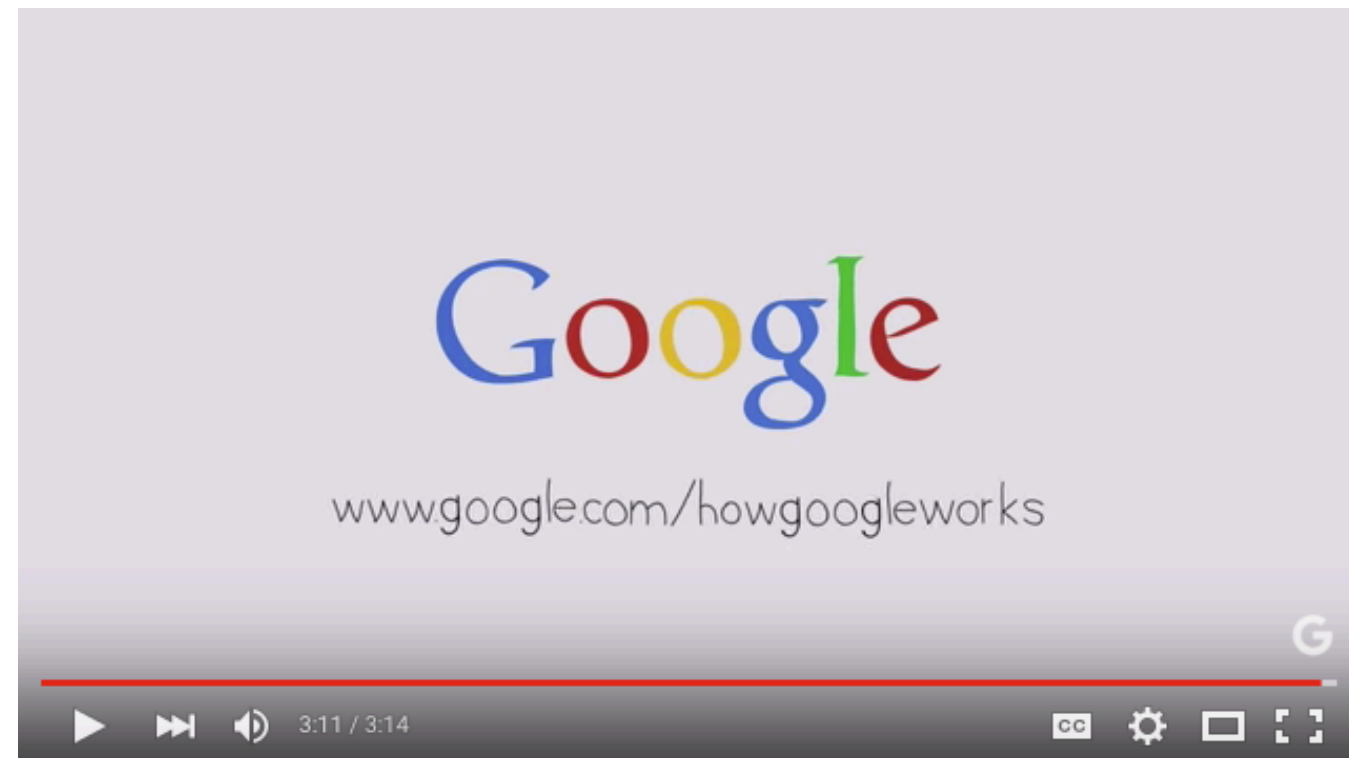



CRAWLING

Copyright violations



Chilling Effects

Home | Weather Reports | Report Receiving
Sending a C&D Notice | Search the Database | Topics

Topic Home | FAQs

Monitoring the legal climate for Internet activity

[Chilling Effects Clearinghouse](#) > [Piracy or Copyright Infringement](#) > Frequently Asked Questions

Frequently Asked Questions (and Answers) about Piracy or Copyright Infringement



• You
Against

<http://chillingeffects.org/piracy/faq.cgi>

- [Q: What is the purpose of copyright law?](#)
- [Q: If I am accused of "piracy," what does this mean?](#)
- [Q: Is all copying piracy?](#)
- [Q: Why is "piracy" such a big issue now?](#)
- [Q: My website contains a disclaimer that clearly states that I do not support or promote copyright infringement. Will this protect me?](#)
- [Q: Why are copyright holders concerned about piracy?](#)
- [Q: What are the penalties for copyright infringement, such as making infringing copies of software?](#)
- [Q: I run a website but I never actually upload or download copyrighted materials. Could I be liable for what visitors to my site do?](#)
- [Q: What is vicarious liability?](#)
- [Q: What is contributory infringement?](#)
- [Q: So am I better off not monitoring my website if I want to avoid contributory infringement liability?](#)
- [Q: Am I protected by Digital Millennium Copyright Act's Safe Harbor?](#)
- [Q: Can I copy or distribute software that is out of print and has been abandoned for years?](#)
- [Q: Aren](#)
- [Q: Isn't sending my friend a music file from a CD I already own just like loaning her the physical CD?](#)
- [Q: Aren't I allowed to make a backup copy of my software?](#)

Samuel
Techno
2006
• [U.S.](#)
[to stop](#)
Press,
• [Nap](#)
[U.S. co](#)
April 20
• [Sch](#)
[crackde](#)
Mendo:
Arizona
• [Holl](#)
[campus](#)
Olsen,
2004



What any crawler should do



- Be capable of **distributed** operation
- Be scalable: need to be able to increase crawl rate by adding more machines
- Fetch pages of higher quality first
- Continuous operation: get fresh version of already crawled pages

How hard can crawling be?



- Web **search engines must crawl** their documents.
- Getting the content of the documents is easier for many other IR systems.
 - E.g., indexing all files on your hard disk: just do a recursive descent on your file system
- Ok: for web IR, getting the content of the documents takes longer . . .
 - . . . because of latency.
- But is that really a design/systems challenge?

Basic crawler operation



- Initialize queue with URLs of known seed pages
- Repeat
 - Take URL from queue
 - Fetch and parse page
 - Extract URLs from page
 - Add URLs to queue
- Fundamental assumption: The web is well linked.



What's wrong with this crawler?

```
urlqueue := (some carefully selected set of seed urls)
while urlqueue is not empty:
  myurl := urlqueue.getlastanddelete()
  mypage := myurl.fetch()
  fetchedurls.add(myurl)
  newurls := mypage.extracturls()
  for myurl in newurls:
    if myurl not in fetchedurls and not in urlqueue:
      urlqueue.add(myurl)
      addtoinvertedindex(mypage)
```

What's wrong with the simple crawler



- Scale: we need to **distribute**.
- We can't index everything: we need to **subselect**. How?
- Duplicates: need to integrate **duplicate detection**
- Spam and spider traps: need to integrate **spam detection**
- **Politeness**: we need to be “nice” and space out all requests for a site over a longer period (hours, days)
- **Freshness**: we need to recrawl periodically.
 - Because of the size of the web, we can do frequent recrawls only for a small subset.
 - Again, subselection problem or **prioritization**

Magnitude of the crawling problem



How Google searches 30 trillion web pages, 100 billion times a month

JOHN KOETSIER, TUNE MARCH 1, 2013 12:43 PM

TAGS: FEATURED, GOOGLE, INDEX, SEARCH ENGINE, WEB SEARCH

To fetch 30T pages in one month, we need to fetch almost 11M pages per second!

Actually many more since many of the pages we attempt to crawl will be duplicates, unfetchable, spam etc.

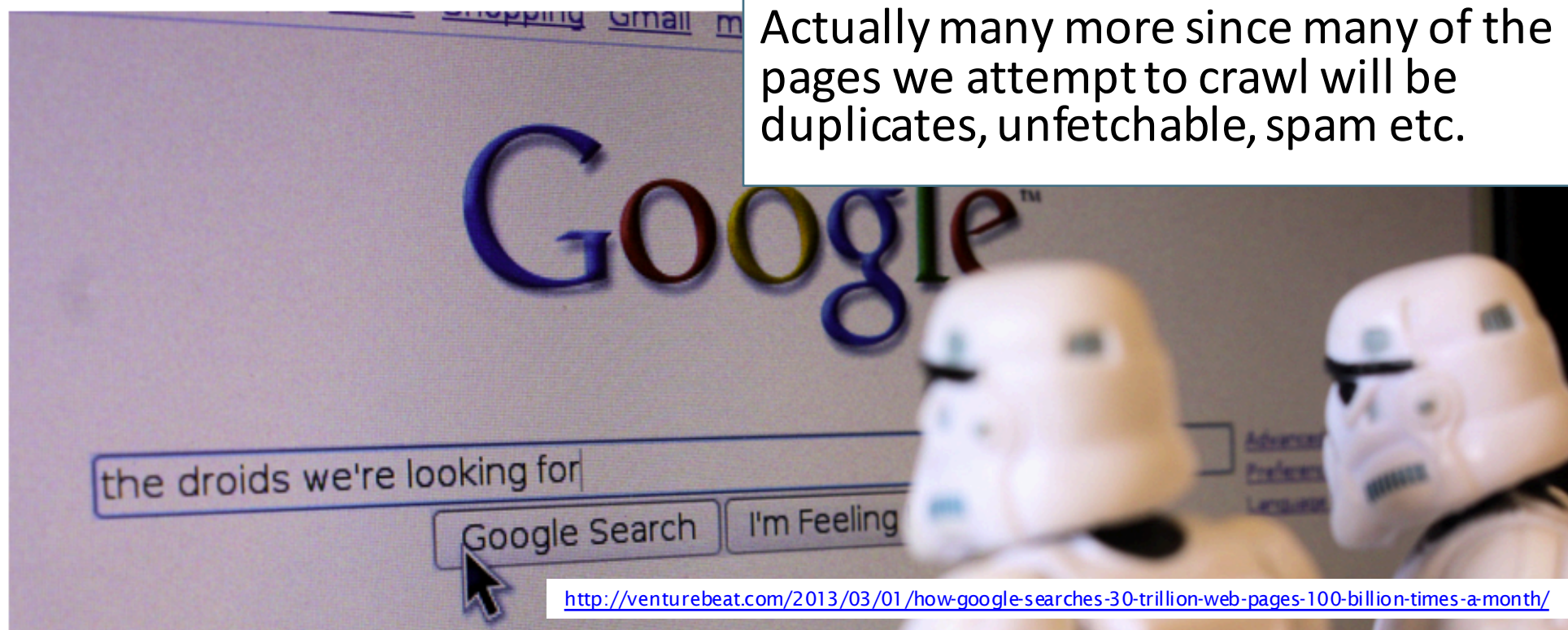

What a crawler must do



Be polite

- Don't hit a site too often
- Only crawl pages you are allowed to crawl: robots.txt

Be robust

- Be immune to spider traps, duplicates, very large pages, very large websites, dynamic pages etc

Robots.txt



- Protocol for giving crawlers (“robots”) limited access to a website, originally from 1994
- Example:
 - User-agent: *
 - Disallow: /yoursite/temp/
 - User-agent: searchengine
 - Disallow: /
- **Important:** cache the **robots.txt** file of each site we are crawling

URL Frontier

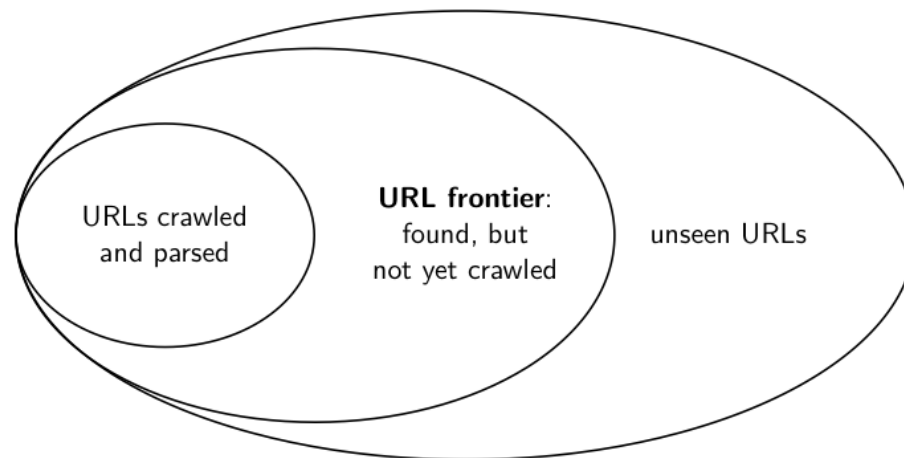

- The URL frontier is the data structure that holds and manages URLs we've seen, but that have not been crawled yet.
- Can include multiple pages from the same host
- Must avoid trying to fetch them all at the same time
- Must keep all crawling threads busy

Basic Crawling Architecture

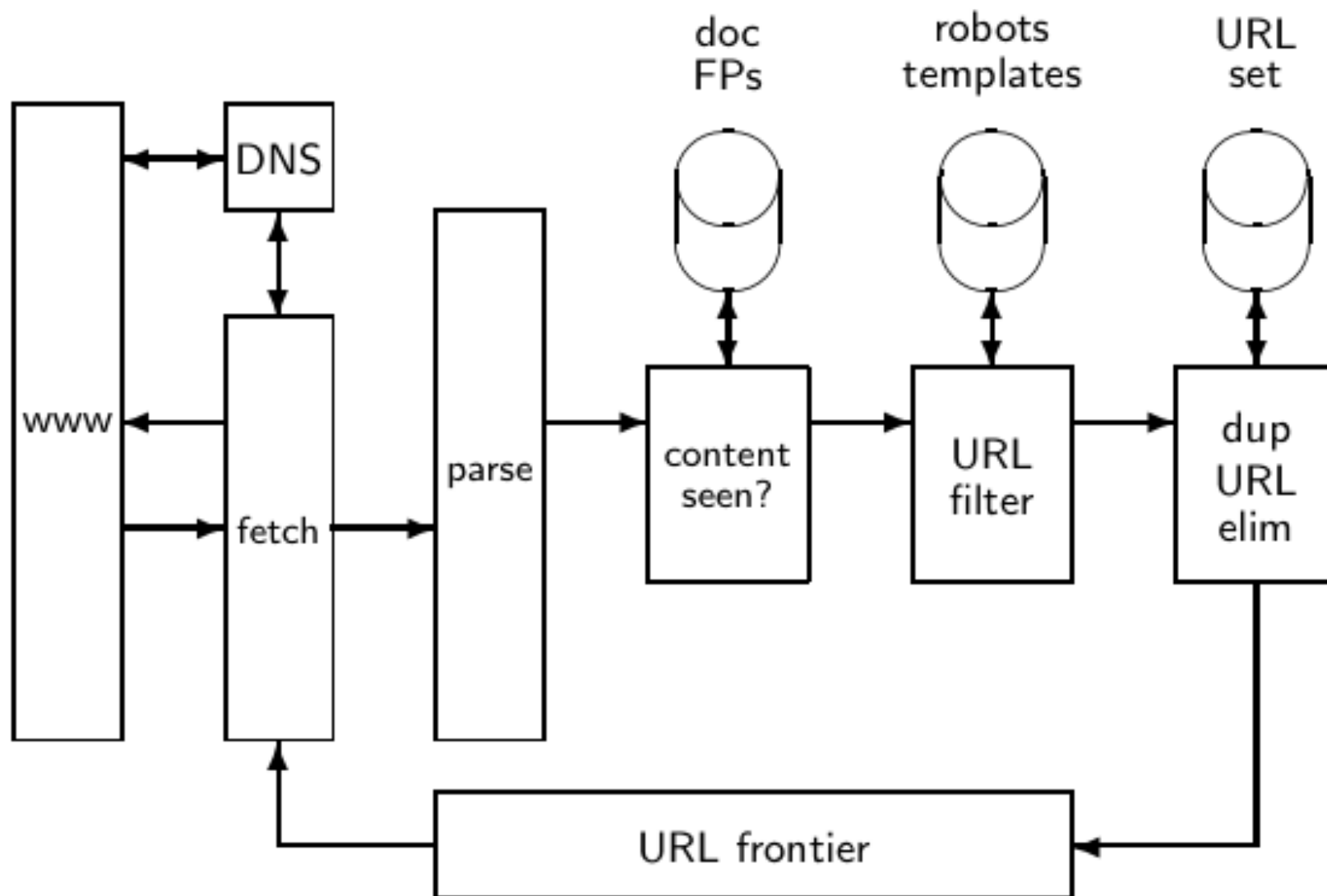



URL normalization

- Some URLs extracted from a document are **relative** URLs.
- E.g., at <http://mit.edu>, we may have <aboutsidesite.html>
 - This is the same as: <http://mit.edu/aboutsidesite.html>
- During parsing, we must normalize (expand) all relative URLs.



Content seen

- For each page fetched: check if the content is already in the index
- Check this using document fingerprints or shingles
- Skip documents whose content has already been indexed
- Still need to consider **Freshness**: Crawl some pages (e.g., news sites) more often than others



Distributing the crawler



- Run multiple crawl threads, potentially at different nodes
 - Usually geographically distributed nodes
- Map target hosts to crawl to nodes

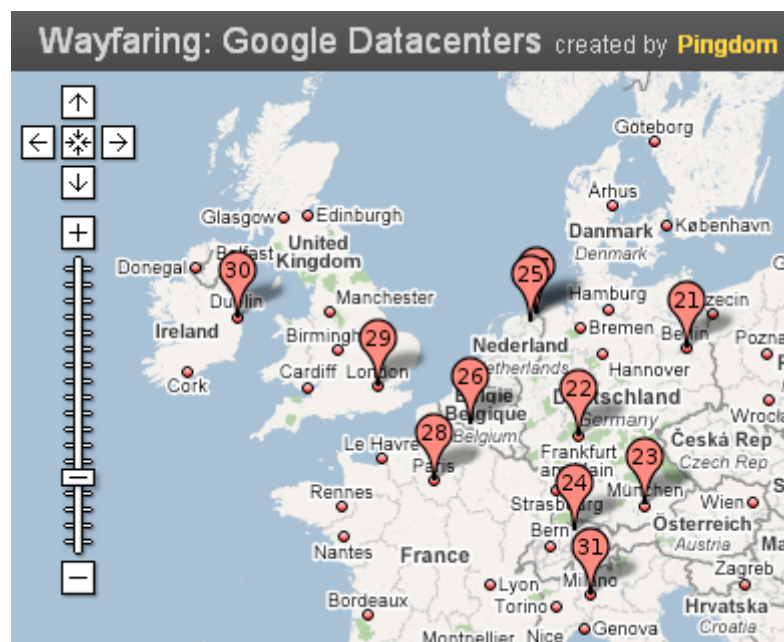

Distributed crawling architecture

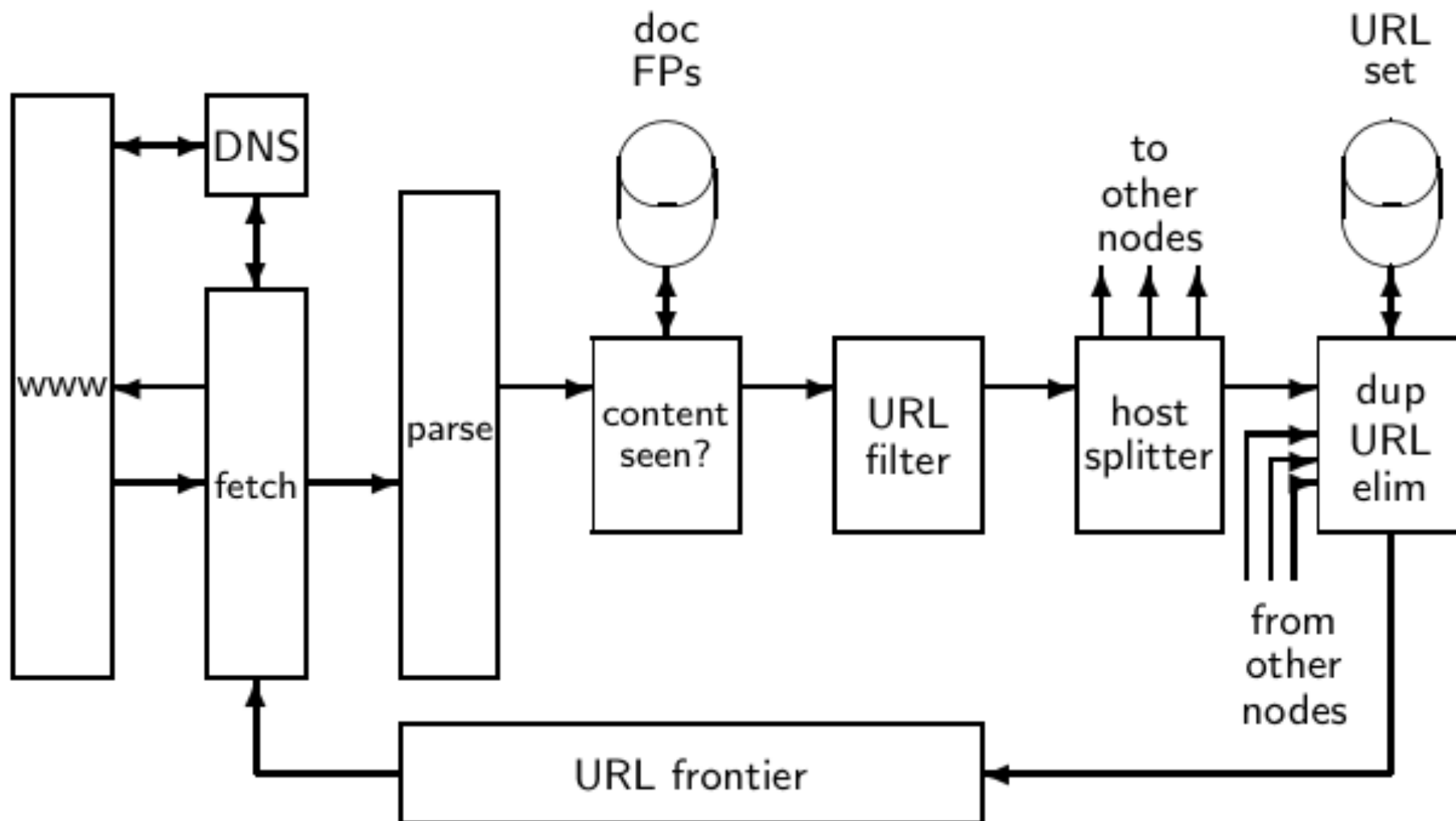

A Crawler Issue: Spider traps



- Malicious server that generates an infinite sequence of linked pages
- Sophisticated spider traps generate pages that are not easily identified as dynamic.



LINK ANALYSIS



The web as a directed graph

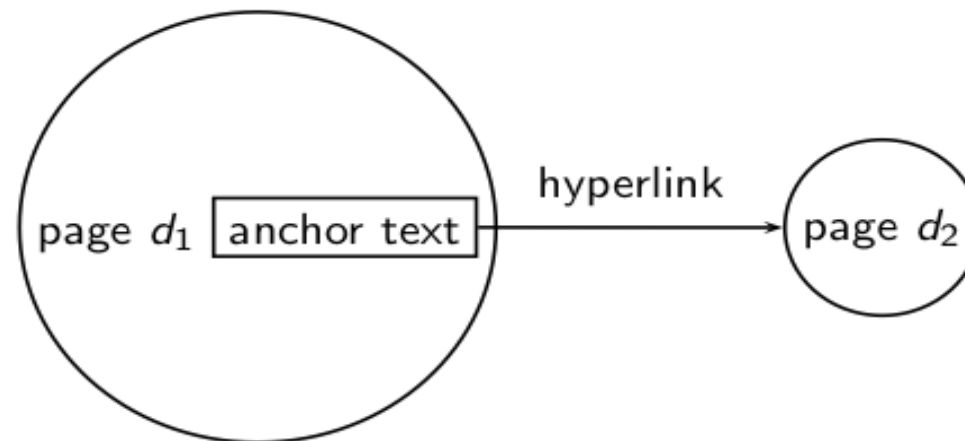

- **Assumption 1: A hyperlink is a quality signal.**
 - The hyperlink $d_1 \rightarrow d_2$ indicates that d_1 's author deems d_2 high-quality and relevant.
- **Assumption 2: The anchor text describes the content of d_2 .**
 - We use anchor text somewhat loosely here for: the text surrounding the hyperlink .
 - Example: “You can find cheap cars `here`. ”
 - Anchor text: “You can find cheap cars here”

[text of d_2] only vs.

[text of d_2] + [anchor text $\rightarrow d_2$]



- Searching on [text of d_2] + [anchor text $\rightarrow d_2$] is often more effective than searching on [text of d_2] only.
- Example: Query *IBM*
 - Matches IBM's copyright page
 - Matches many spam pages
 - Matches IBM wikipedia article
 - May not match IBM home page!
... if IBM home page is mostly graphics
- Searching on [anchor text $\rightarrow d_2$] is better for the query *IBM*.
 - In this representation, the page with most occurrences of *IBM* is www.ibm.com

Anchor text containing *IBM* pointing to www.ibm.com



www.nytimes.com: “IBM acquires Webify”

www.slashdot.org: “New IBM optical chip”

www.stanford.edu: “IBM faculty award recipients”

www.ibm.com

Indexing anchor text



- Thus: Anchor text is often a better description of a page's content than the page itself.
- Anchor text can be weighted more highly than document text.
(based on Assumption 1 & 2)

Aside: we use this in academic networks too. Citances (“sentences that cite another work”) and their host document sections are more useful in categorizing a target work. (*cf* Assumption 1)



Assumptions underlying PageRank

- Assumption 1: A link on the web is a quality signal – the author of the link thinks that the linked-to page is high-quality.
- Assumption 2: The anchor text describes the content of the linked-to page.
- Is Assumption 1 true in general?
- Is Assumption 2 true in general?

Google bombs



- Is a search with “bad” results due to maliciously manipulated anchor text.
- E.g., [dangerous cult] on Google, Bing, Yahoo
 - Coordinated link creation by those who dislike the Church of Scientology
- Google introduced a new weighting function in January 2007 that fixed many Google bombs.
- Defused Google bombs: [who is a failure?], [evil empire]

A screenshot of a Google search page for the query "dangerous cult". The search results show several links related to the Church of Scientology and other cult-related topics. The top result is "Scientology - Church of Scientology Official Site" with a snippet about living in a dangerous environment. Other results include "The Most Dangerous Cult in The World by Laura Knight-Jadczyk" and "Dangerous Cult Warning Signs". The search bar shows the query "dangerous cult" and the search button is visible. The page also features a "BloomSEO" logo in the top right corner of the search results area.

Web Images Maps News Shopping Gmail more

Google dangerous cult Search

Web Results 1 - 10 of about 252,000 for **dangerous cult**. (0.06 se

[Scientology - Church of Scientology Official Site](#)
Living in a **Dangerous** Environment · Drug and Alcohol Problems · Personalities, Emot
and How to Deal with Others ...
[www.scientology.org/](#) - 73k - [Cached](#) - [Similar pages](#) - [Note this](#)

[The Most **Dangerous Cult** in The World by Laura Knight-Jadczyk](#)
There's a new religious **cult** in America. It's not composed of so-called "crazies" so mu
mainstream, middle to upper-middle class Americans. ...
[www.cassiopaea.org/cass/Laura-Knight-Jadczyk/fastest_growing_cult.htm](#) - 144k -
[Cached](#) - [Similar pages](#) - [Note this](#)

[Dangerous Cult Warning Signs](#)
If you, or a loved one, are in a **dangerous cult**, as determined by the above checklist,
must do everything you possibly can to remove the potential ...
[www.vistech.net/users/rsturge/cults.html](#) - 4k - [Cached](#) - [Similar pages](#) - [Note this](#)

[The Watchman Expositor: The Most **Dangerous Cult** in America](#)
However, when the world's final chapter is written, which will prove to be "THE most
dangerous cult in America?" One of the cults mentioned above? ...
[www.watchman.org/rektop/budcomp.htm](#) - 10k - [Cached](#) - [Similar pages](#) - [Note this](#)



PAGERANK

Origins of PageRank: Citation analysis – 1



- Citation analysis: analysis of citations in the scientific literature.
- Example citation: “[Miller \(2001\)](#) has shown that physical activity alters the metabolism of estrogens.”
- We can view “Miller (2001)” as a hyperlink linking two scientific articles.
- One application of these “hyperlinks” in the scientific literature:
 - Measure the similarity of two articles by the overlap of other articles citing them.
 - This is called [cocitation similarity](#).
 - Cocitation similarity on the web: Google’s “find pages like this” or “Similar” feature.



Citation analysis – 2

- Another application: Citation frequency can be used to measure the **impact** of an article.
 - Simplest measure: Each article gets one vote – not very accurate.
- On the web: citation frequency = **in-link count**
 - A high inlink count does not necessarily mean high quality ...
... mainly because of link spam.
- Better measure: **weighted** citation frequency or citation rank
 - An article's vote is weighted according to its citation impact.
 - Circular? No: can be formalized in a well-defined way



Citation analysis – 3

- Better measure: weighted citation frequency or citation rank, invented in the context of citation analysis by Pinski and Narin in the 1960s.
- This is basically PageRank.
- We can use the same formal representation for
 - citations in the scientific literature
 - hyperlinks on the web
- Appropriately weighted citation frequency is an excellent measure of quality ...
... both for web pages and for scientific publications.



Definition of PageRank

- The importance of a page is given by the importance of the pages that link to it.

$$x_i = \sum_{j \in B_i} \frac{1}{N_j} x_j$$

importance of page i

pages j that link to page i

importance of page j

number of outlinks from page j

Pagerank scoring



- Imagine a browser doing a random walk on web pages:
 - Start at a random page
 - At each step, follow one of the n links on that page, each with $1/n$ probability
- Do this repeatedly. Use the “long-term visit rate” as the page’s score
- This is a global score for the page, based on the topology of the network.
- Think of it as $g(d)$ from Chapter 7

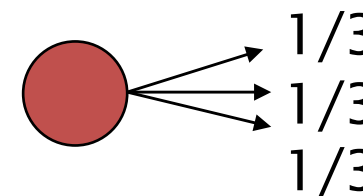

Markov chains



A Markov chain consists of n states, plus an $n \times n$ transition probability matrix A .

- At each step, we are in exactly one of the states.
- For $1 \leq i, k \leq n$, the matrix entry A_{ik} tells us the probability of k being the next state, given we are currently in state i .
- **Memorylessness property**: The next state depends only at the current state (first order Markov Chain)

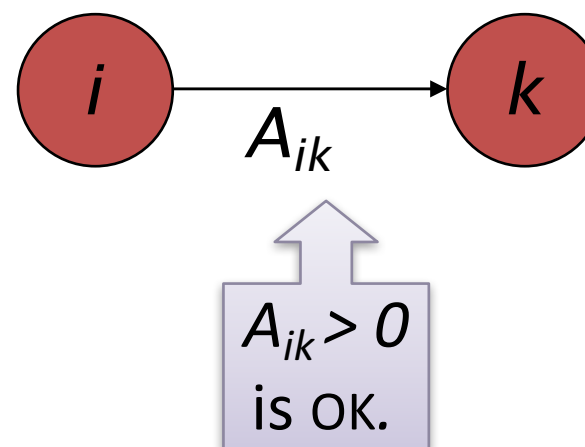



Markov chains

- Clearly, for all i , $\sum_{k=1}^n A_{ik} = 1$.
- Markov chains are abstractions of random walks

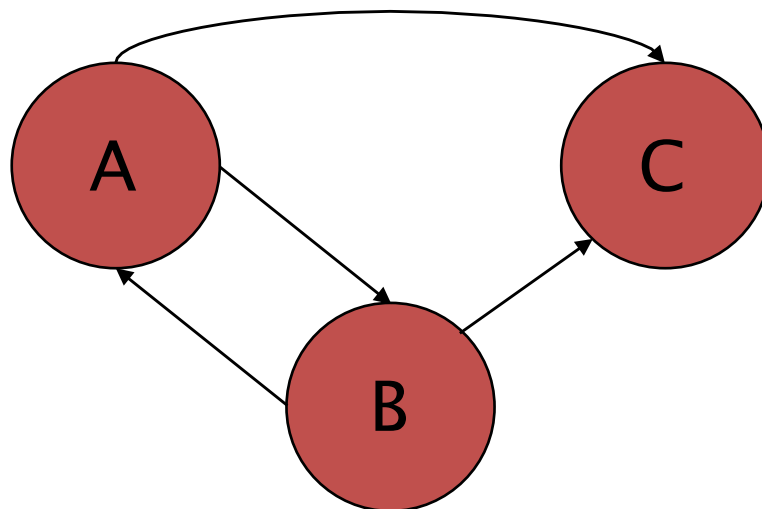

Try this: Calculate the matrix A_{ik} using $1/n$ possibility

A_{ik} :

	A	B	C
A			
B			
C			



Not quite enough

- The web is full of dead ends.
 - What sites have dead ends?
 - Our random walk can get stuck.

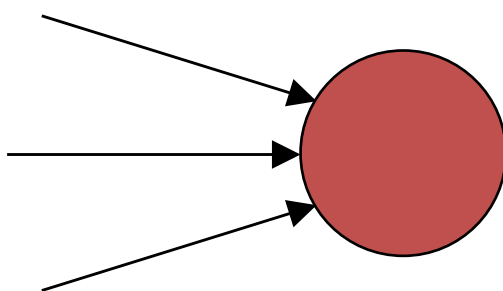

Dead End

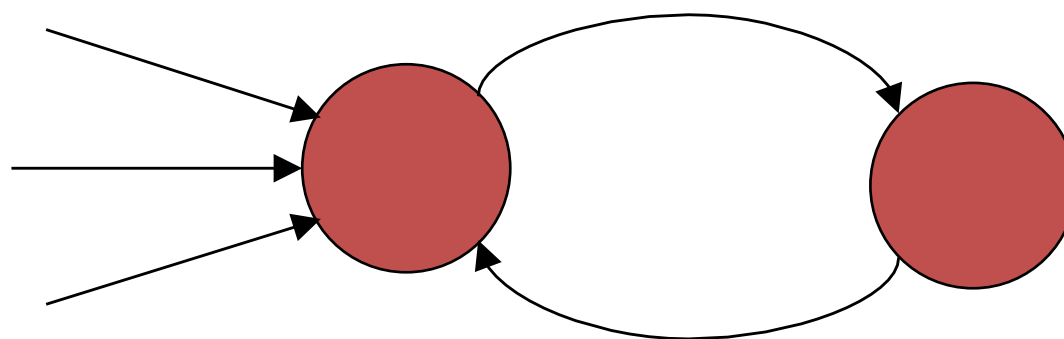

Spider Trap



Teleporting

- At each step, with probability 10%, teleport to a random web page
- With remaining probability (90%), follow a random link on the page
 - If a dead-end, stay put in this case

Follow! →

$$\vec{rank} = (1 - \alpha) A \times \vec{rank} + \alpha \left[\frac{1}{N} \right] N \times 1$$

Teleport!

Ergodic Markov chains



- A Markov chain is ergodic if
 - you have a path from any state to any other
 - you can be in any state at every time step, with non-zero probability

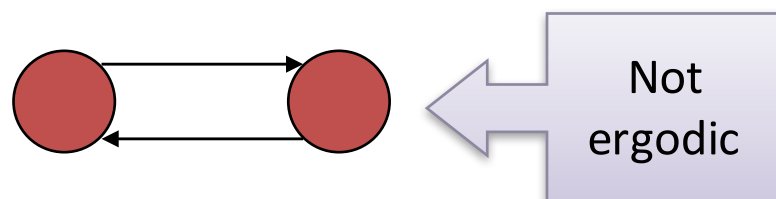

- With teleportation, our Markov chain is ergodic
- Theorem: With an ergodic Markov chain, there is a stable long term visit rate.

Markov chains (2nd Try)

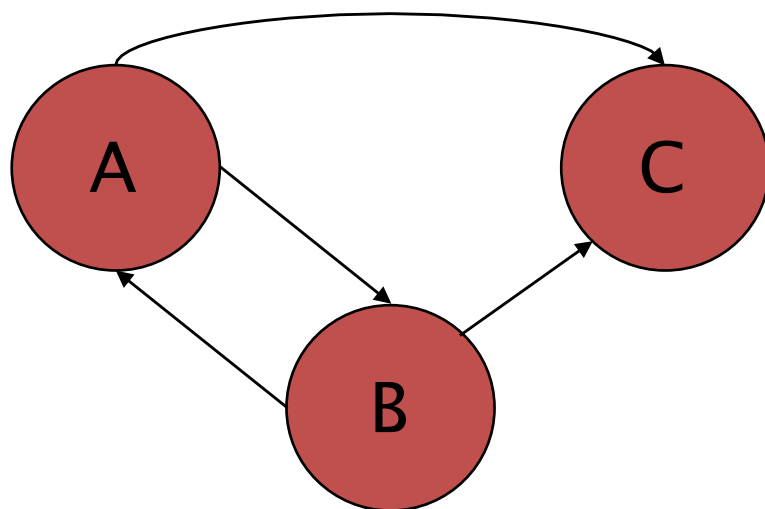

Try this: Calculate the matrix A_{ik} using a 10% chance of teleportation

A_{ik} :

	A	B	C
A			
B			
C			

Probability vectors



- A probability (row) vector $\mathbf{x} = (x_1, \dots, x_n)$ tells us where the walk is at any point
- E.g., $(\underset{1}{000}\dots\underset{i}{1}\dots\underset{n}{000})$ means we're in state i .

More generally, the vector $\mathbf{x} = (x_1, \dots, x_n)$ means
The walk is in state i with probability x_i .

$$\sum_{i=1}^n x_i = 1.$$

Change in probability vector



- If the probability vector is $\mathbf{x} = (x_1, \dots, x_n)$ at this step, what is it at the next step?
- Recall that row i of the transition prob. Matrix \mathbf{A} tells us where we go next from state i .
- So from \mathbf{x} , our next state is distributed as $\mathbf{x}\mathbf{A}$.

Pagerank algorithm



- Regardless of where we start, we eventually reach the steady state a
 1. Start with any distribution (say $x=(10\dots0)$).
 2. After one step, we're at Ax .
 3. After two steps at A^2x , then A^3x and so on.
 4. “Eventually” means for “large” k , $A^kx = a$.

- Algorithm: multiply x by increasing powers of A until the product looks stable.

Steady State



- For any ergodic Markov chain, there is a unique long-term visit rate for each state
 - Over a long period, we'll visit each state in proportion to this rate
 - It doesn't matter where we start

Eigenvector formulation



- The flow equations can be written

$$\mathbf{r} = \mathbf{A}\mathbf{r}$$

- So the rank vector is an eigenvector of the adjacency matrix
 - In fact, it's the first or principal eigenvector, with corresponding eigenvalue 1

PageRank summary



- Pre-processing:
 - Given graph of links, build matrix A
 - From it compute α
 - The pagerank a_i is a scaled number between 0 and 1
- Query processing:
 - Retrieve pages meeting query
 - Rank them by their PageRank
 - Order is *query-independent*

PageRank issues



- Real surfers are not random surfers.
 - Examples of nonrandom surfing: back button, short vs. long paths, bookmarks, directories – and search!
→ Markov model is not a good model of surfing.
 - But it's good enough as a model for our purposes.
- Simple PageRank ranking (as described on previous slide) produces bad results for many pages.
 - Consider the query [video service].
 - The Yahoo home page (i) has a very high PageRank and (ii) contains both *video* and *service*.
 - If we rank all Boolean hits according to PageRank, then the Yahoo home page would be top-ranked.
 - Clearly not desirable.



How important is PageRank?

- Frequent claim: PageRank is the most important component of web ranking.
- The reality:
 - There are several components that are at least as important: e.g., anchor text, phrases, proximity, tiered indexes ...
 - PageRank in its original form (as presented here) has a negligible impact on ranking.
 - However, variants of a page's PageRank are still an essential part of ranking.
 - Addressing link spam is difficult and crucial.



Summary

- Crawling – Obtaining documents for indexing
 - Need to be polite
- PageRank – A $G(d)$ for asymmetrically linked documents
- Chapters 20 and 21 of IIR
- Resources
 - Paper on [Mercator crawler](#) by Heydon et al.
 - [Robot exclusion standard](#)

“PageRank reflects our view of the importance of web pages by considering more than 500 million variables and 2 billion terms. Pages that believe are important pages receive a higher PageRank and are more likely to appear at the top of the search results”